

Developing a Custom Remote Sensing Solution for Nuclear Power Plants

Introduction

Nuclear power plants present many unique challenges for networked monitoring of equipment, as well as enormous potential advantages in terms of safety and cost savings. Benchmark joined with industry software leader KnowledgeRelay to create a custom Multi-Sensing Monitoring Unit (MSMU) for Idaho National Laboratory. The resulting MSMU uses sensors and advanced machine learning to monitor equipment in nuclear power plants across the U.S. by sensing vibrations. The technology effectively reduced the need for manual surveillance, which lowers costs and improves the plant's safety. This case study examines the challenges, solutions, and results of the project.

The Challenge

Idaho National Laboratory (INL) is part of the U.S. Department of Energy's complex of national laboratories and the nation's leading center for nuclear energy research and development. The lab is focused on developing solutions implemented at nuclear power plants across the U.S. Typically, more than 80% of work performed in a U.S. Nuclear power plant (NPP) is associated with preventative maintenance activities and monitoring of equipment. Consistent monitoring of equipment is a legal requirement of a plant's license and essential for the safety of workers and the facility.

INL undertook a project to create a targeted surveillance solution for its residual heat removal (RHR) pumps. The lab's conventional process for monitoring these pumps is a labor-intensive manual activity. Most of this equipment is older and lacks the typical IoT sensors that are common in new machinery. After the pump starts, operating conditions such as pressure and flow rates are established, and technicians use probes connected to portable vibration-monitoring devices to acquire vibration, temperature, and acoustic measurements.



RHR pumps are large and tall, so to reach the pumps, technicians must use a ladder to place probes on fixed locations. The RHR pumps are also difficult to access in general due to their location and high levels of radioactivity. The entire process is time-consuming, labor-intensive, and expensive.

Ultimately, INL needed an automated solution that would limit the need for technicians to be onsite and reduce the amount of work required to monitor the equipment. The lab's management assessed the technology that was currently available on the market and looked for a solution that could accomplish the following:

1. Start when the equipment starts and shut down when the equipment shuts down
2. Generate data in the raw form
3. Store the data locally
4. Take measurements on demand

- Utilize a secure communication method to transfer data from sensors, without interfering with existing wireless connectivity already in use
- Be reconfigurable and adaptable

A gap analysis conducted by INL revealed that solutions for continuous monitoring of equipment were already available through several vendors. However, most surveillance equipment (such as RHR pumps) is considered standby equipment. They don't run under normal conditions and therefore lack a suitable technology solution to monitor them. A set of standby monitoring units was deemed necessary but not available in existing markets. INL reached out to KnowledgeRelay and Benchmark to develop a custom solution.

Solution

INL first approached KnowledgeRelay with this challenge because of their vast experience with advanced systems integration, data migration, and decision support systems for the industrial sector. The company's team understood the data and sensing challenge at hand needed to reduce the expensive and dangerous maintenance practices nuclear power plants had been conducting on RHR pumps.

KnowledgeRelay established a partnership with Benchmark because of our work in defense applications with connected soldier systems and other military sensor networks. Benchmark's challenge was to leverage this experience to create a system that integrated the sensor network and organized disparate data sources to get refined data to the right people.

To begin, Benchmark leveraged its Advanced Technology Group (AT) to research potential solutions to this unique challenge. The AT performs much of Benchmark's key R&D initiatives when a customer comes to Benchmark with a problem that currently offers no definitive solutions in the marketplace.

Knowledge Relay and Benchmark investigated use of a connected temperature, acoustic, and vibration-based sensor unit to match one-for-one the handheld equipment used by maintenance workers. The resulting technology is a customized multi-sensor monitoring unit (MSMU) that effectively monitors the RHR pumps

Simplified diagram of sensor network architecture

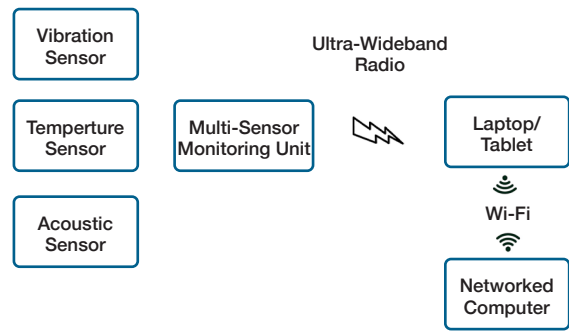

using sound, vibrations, and temperature. The MSMU connects to several commercially available sensors. The solution works by using a phased array that directs the signal precisely, rather than relying on a broad emitting signal that may lead to inaccurate data.

The MSMU is connected to the RHR pump via magnets and left on standby until the unit begins running. The MSMU powers up in unison with the RHR pump and collects data via the three sensors connected to the transmitter. This standby power-up feature prevents the unit from draining the battery too quickly.

Benchmark also developed the firmware and middleware that helped gather the data and put it into a usable format for KnowledgeRelay's machine learning algorithm. The algorithm collects data on how the RHR pumps sound during normal operation and can then identify how they sound when something goes wrong and notify maintenance.

Multi-Sensor Monitoring Unit (MSMU)

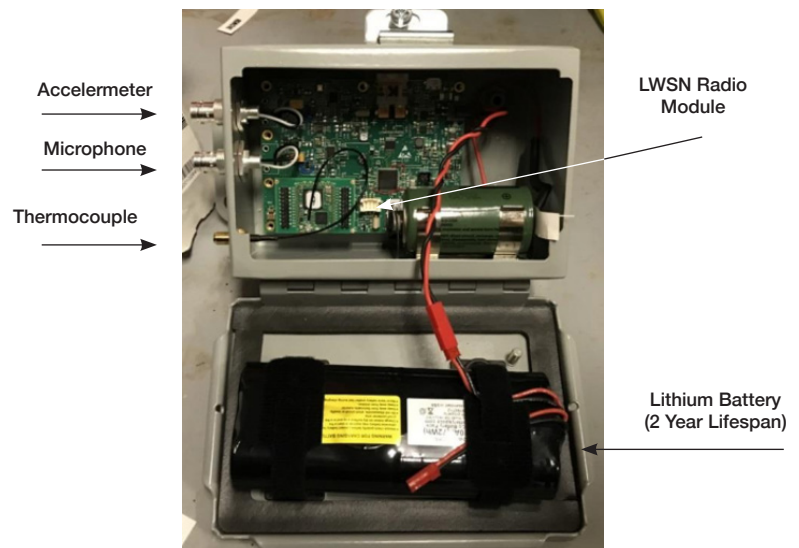

One of the project's critical challenges was the inability to run wiring to the unit that would both send data and power to the system. Wireless options needed to be secure and not interfere with existing wireless signals used in a nuclear power plant to be feasible.

Benchmark designed the MSMU so that the transmitter communicates with a computer through a battery-powered interfacing transmitter connected over a secure ultra-wideband radio network. In addition to being secure and difficult to jam, ultra-wideband does not interfere with any existing wi-fi, Bluetooth, hand-held radio, or other radio frequency devices in the facility. All data is stored locally and securely, and the battery can power the unit for up to two years before a replacement is necessary.

Ultimately, the system is designed to monitor the RHR pumps whenever they are operating and securely transmit data to plant workers. The MSMU will alert staff when anything out of the ordinary is detected, all through monitoring sound, vibrations, and temperature.

The Results

The MSMU was first piloted on a fire protection pump as it has the same function as the RHR pump but is more accessible and less critical. This allowed INL to see the MSMU in action and develop deep confidence in its ability to function as designed. This pilot program also allowed them to benchmark the MSMU in terms of data, quality, use, and applications to gain insights into how it functions and how remote sensors might be used in other areas of the plant.

At its conclusion, the project was deemed a success. The custom MSMU developed by KnowledgeRelay and Benchmark met all six of the requirements INL outlined at the beginning of the project. The custom MSMU started and shut down with the RHR pump, consistently generated data in raw form, stored that data locally, took measurements on demand, was secure, and could be easily configured and adapted to different equipment types.

Sensor unit installed on an RHR pump



The MSMU is now being used on RHR pumps, offering safe operations for nuclear power plants and the communities they serve while creating a safer and more cost-effective work environment. INL and nuclear plants across the U.S. are working to replace the manual process for monitoring RHR pumps. They are also evaluating an expansion of the project to use vibration and contactless sensors to monitor other types of equipment in closed environments in nuclear plants.

For a more detailed report on this project, please refer to the U.S. Department of Energy's September 2019 36-page report titled "Automating Surveillance Activities in a Nuclear Power Plant." Available at https://lwrs.inl.gov/Advanced%20IIC%20System%20Technologies/Automating_Surveillance_Activities_in_%20Nuclear_Power_Plant.pdf